**Application**

- Check-in
- Repair and maintenance
- Wheel alignment
- Testing equipment

Approvals

- Jaguar
- Landrover

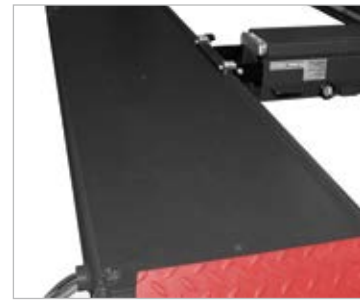

Major 4030

Electro-hydraulic 4-post lift, 4 t capacity

Description:**Posts:**

- Integrated eccentric brake system
- Emergency stop valve
- Obstruction system
- Pneumatic parking system in height adjustable ratchets
- Pump and control unit on rear left post
- Pushbutton control unit with alarm signal
- Hydraulic cylinder under left platform
- Lifting and lowering by means of cables
- Emergency lowering valve

Superstructure:

- One movable platform as standard
- Platforms prepared for AUTOPSTENHOJ Scissor jack Micro

Standard colours

- Platforms & posts: Grey RAL 7016
- Ramps: Red RAL 3020

Optional extras:

- Set of expansion bolts
- Extra control unit
- LED-Lighting set
- Set of two cover plates for recesses
- Set of two 385 mm ramp extensions
- Set of two platform extensions (0.5 m)

Special colours available on request!

Technical data	
Lifting capacity	4,000 kg
Lifting height	1,670 mm
Working height	1,810 mm
Lifting / lowering time	Standard: 24 / 26 Sec. D: 16 / 26 Sec.
Pump unit	Standard: 3.0 kW D: 2 x 3.0 kW
Voltage	3x230/400V-50 Hz - 25/16 A

Platforms	
Total length	5,560 / 5,980 mm
Usable length of platform	4,680 / 5,100 mm
Wheel base, min. - max.	variabel
Platform width	550 mm
Distance between platforms	805 - 1,285 mm
Min. height	140/160 mm
Width between posts	3,000 mm
Total width - outer edges posts	3,422 mm
Total height	2,233 mm

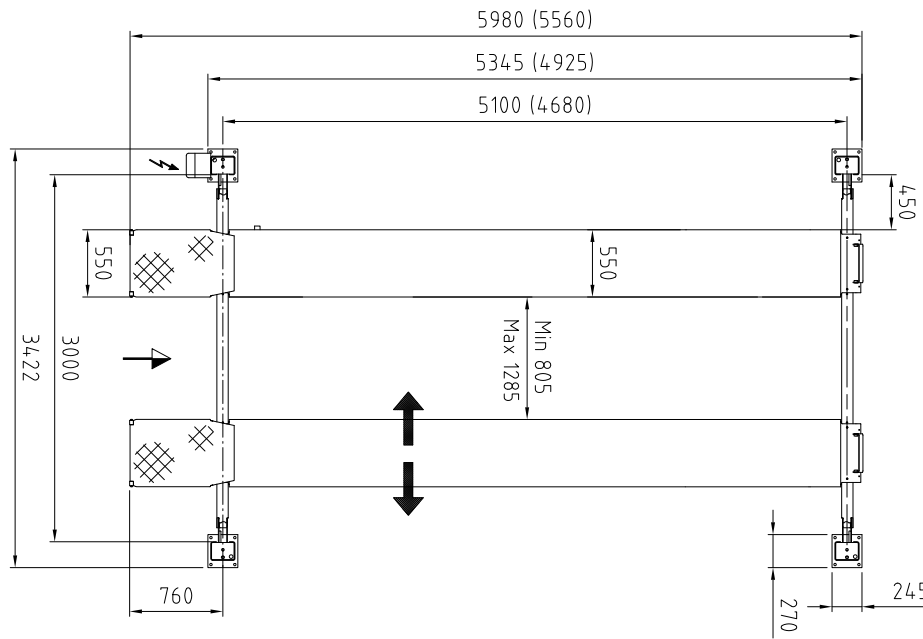

Scan the QR-Code for detailed product information.

Further Information on www.autopstenhoj.com

Versions:

- Available with different Voltage
- Drive-on ramps and stops for surface-mounting, alternatively drive-over ramps for recessed installation

Installation:

- S = flush platforms
- W = with front recesses for turn tables and rear side slip plates
- G = galvanized platforms
- 42 = 4,200 mm platforms
- 47 = 4,700 mm platforms
- 51 = 5,100 mm platforms

Inspection lifts:

As standard equipped with re-inforced posts and larger cable diameter for intensive usage in inspection centres. As standard delivered with:
 P = play detector (pneumatically operated for both lateral and rotational movement, for axle load up to 3 t), operation with wireless hand lamp Option:
 D = double pump unit for quicker lifting time. Control unit on front left post

MOT / ATL lifts:

Worldwide accepted inspection lifts which have been specified and constructed according to UK MOT and ATL (automated test lanes DVSA) requirements. Both MOT / ATL lifts are as standard delivered with front recesses with turntables and extra control unit for operation from front right post; ATL lifts furthermore equipped with re-inforced posts and larger cable diameter and:
 P = play detector (pneumatically operated for both lateral and rotational movement, for axle load up to 3 t), operation with wireless hand lamp