



AC Hydraulic^{A/S}
NO COMPROMISE





HYDRAULIC JACKS

DK20HLQ



Capacity: 2,0 t
Max. height: 795 mm

High lifting jack ideal for SUVs and vans

- Very low minimum height of only 80 mm
- Wide and robust frame made of high-strength steel
- Fitted with quick-lift pedal for easy reach of lifting point
- Precise and safe control whilst lowering
- Manual dead man's release for optimum safety when lowering
- Built-in safety overload valve
- Noiseless wheels incorporating a polyurethane central O ring offers maximum surface protection
- Ergonomically designed handle ensuring positive and safe operation



DK50HLQ



Capacity: 5,0 t
Max. height: 975 mm

High lifting jack for trucks, agricultural machinery & contractors' machines

- Low minimum height of only 140 mm
- Can be fitted with pneumatic tyres for easy manoeuvring (option)
- Wide and robust frame made of high-strength steel
- Fitted with quick-lift pedal for easy reach of lifting point
- Precise and safe control whilst lowering
- Manual dead man's release for optimum safety when lowering
- Built-in safety overload valve
- Ergonomically designed handle ensuring positive and safe operation



DK20HLQ

DK50HLQ

	DK20HLQ	DK50HLQ
Capacity	2,0 t	5,0 t
Min. height	80 mm	140 mm
Max. height	795 mm	975 mm
Frame length	950 mm	1290 mm
Handle length	950 mm	1200 mm
Frame height	220 mm	265 mm
Width	500 mm	525 mm
Weight	49 kg	170 kg

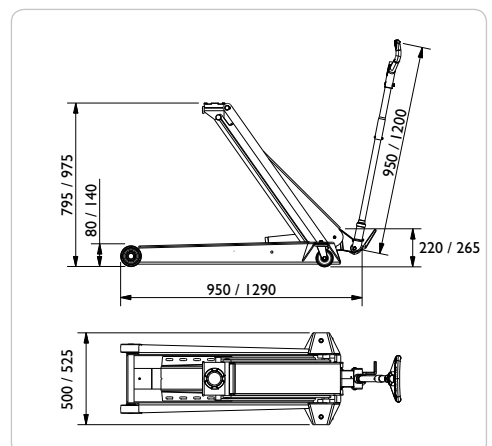



OPTION - HYDRAULIC JACKS

GSI



Rubber cushion
For protection of car body

Fits:
DK20
DK20Q
DK13HLQ
DK20HLQ
T3



G4



High quality pneumatic tyres
For easy transport and extra manoeuvrability – also on uneven floors

Fits:
DK40Q
DK60Q
DK100Q
DK120Q
DK50HLQ



T3

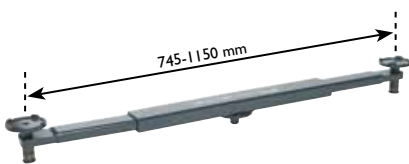

Capacity: 1,0 t

Cross beam adaptor
Lifts the car for change of both wheels at the same time
With telescopic arms, reach from 745 – 1150 mm

Fits:
DK20
DK20Q
DK13HLQ
DK20HLQ



FDK1 / FDK2



Extension FDK1
Extension for cars with high clearance (100 mm)

Fits:
DK20 / DK20Q
DK13HLQ / DK20HLQ

Extension FDK2
Extension for cars with high clearance (125 mm)

Fits:
DK40Q / DK60Q
DK100Q/DK120Q/DK50HLQ





GEMCO Equipment Ltd
153 - 165 Bridge Street, Northampton, NN1 1QG
t: 01604 828600
e: sales@gemco.co.uk w: www.gemco.co.uk