



AC Hydraulic^{A/S}
NO COMPROMISE





WHEEL TROLLEYS

WT1500



Capacity: 1,5 t

Mechanical wheel trolley for tractors, agricultural and contractors' machinery

Ergonomically designed for the easy and efficient removal of large wheels - also deep-treaded tractor tyres

Side-adjustable lifting arms for wheel diameters ranging 920-2300 mm

Robust safety wheel retaining bracket for the safe manoeuvring of the trolley

Precise and easy lifting and lowering by means of mechanical operation

Excellent manoeuvrability due to the 4 large, heavy-duty revolving wheels

Lifting arms fitted with 3 roller bearings for ensuring the easy location of wheels



WT1500

Capacity	1,5 t
Height	1360 mm
Length	1160 mm
Width	1680 - 2380 mm
Roller length	740 mm
Roller distance	720 - 1380 mm
Roller diameter	Ø 80 mm
Wheel sizes	Ø 920 - 2300 mm
Weight	150 kg

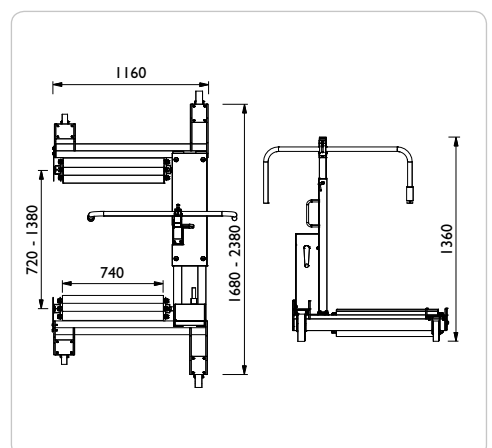



GEMCO Equipment Ltd
153 - 165 Bridge Street, Northampton, NN1 1QG
t: 01604 828600
e: sales@gemco.co.uk w: www.gemco.co.uk