

Application

- Repair and maintenance
- Body work

Approvals

- All models:
 - Renault
- Saa 230:
 - Volkswagen Group
- Saa 265:
 - Mercedes-Benz
 - Volkswagen Group

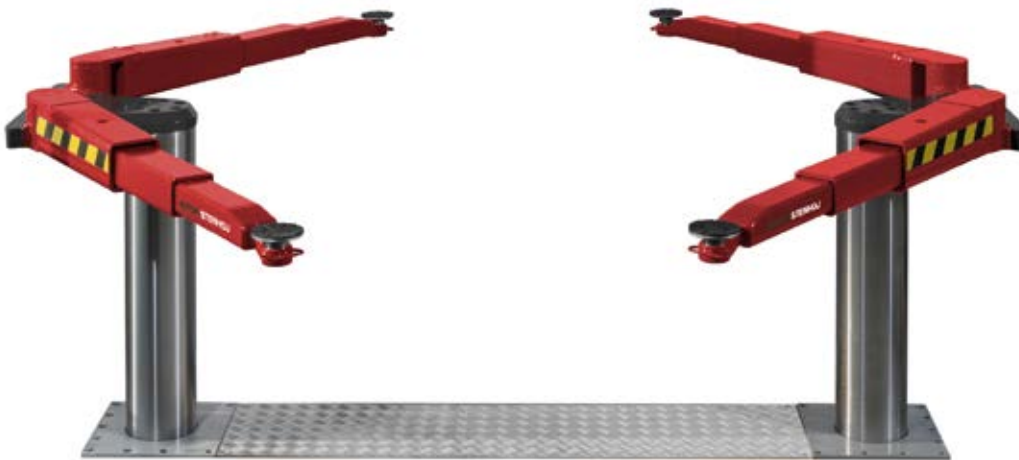

Biglift 2.50 Saa

Electro-hydraulic twin-ram lift, 5 t with superstructure with arms

Description:

Steel cassette:

- Waterproof steel cassette

Hydraulic unit:

- Hard-chrome plated cylinder
- Flexible synchronization and safety system
- Corrosion-free guiding elements
- Pump unit with immersed motor
- Ecological hydraulic fluid
- Pneumatic emergency lowering
- Programmable pushbutton control unit – great stability, even with uneven weight distribution; due to the cylinder diameter of 213 mm

Superstructure:

- Double telescopic arms
- Internal arm locking system
- Low minimum height

Saa 265:

- Mechanical ratchet system integrated in the hydraulic unit
- Necessary air pressure (clean, dry, lubricated): min. 6 bar / max. 10 bar

Standard colours

- Base plate: Grey RAL 7016
- Arms: Red RAL 3020

Technical data	
Lifting capacity	5,000 kg
Lifting height	1,865 mm
Working height	2,005 - 2,065 mm
Cylinder diameter	2 x 213 mm
Distance between cylinders	Saa 230: 2.150 mm Saa 265: 2.650 mm
Lifting / lowering time	app. 45 Sec.
Foundation depth	2,625 mm
Pump unit	3.0 kW
Ecological hydraulic fluid	18 l
Voltage	230/400 V - 50 Hz - 16 A

Arm superstructure	
Total width	2,950 mm
Lifting pad included in the delivery	11028 (135 - 195 mm)
Min. height	135 - 195 mm
Drive-through width	Saa 230: 1,930 mm Saa 265: 2,430 mm
Arm length, min. - max.	715 - 1,410 mm

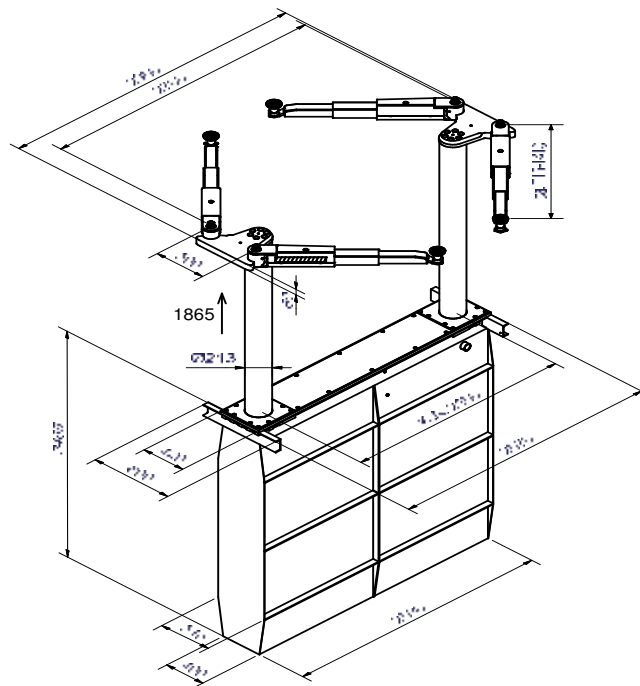

Scan the QR-Code for detailed product information.

Further Information on www.autopstenhoj.com

Versions:

- Saa 230 & Saa 265

Steel cassette:

- Zinc-coated
- Coated
- Self-carrying (Saa 230)

Installation:

- Superstructure on floor
- Superstructure in floor with covers (Saa 230)
- Ceiling installation (Saa 230)

Optional extras:

- Large program of extra pads

Special colours available on request!